

SHOW

« ENTRE NOUS... »

TECHNIQUE SHEET

*Show for 4 artists
Length of the show: 45 minutes
Audience between 200 and 1500 persons*

This technical sheet is an integral part of the contract. It must be initialled and signed in the same way as the rest of this contract. In case of difficulty to honour it, thank you to contact our team, at least 1 month before the date of the show.

Contents

Touring team and Contacts	2
Logistic and welcoming	3
Travel	3
Dressing rooms and Catering	3
Costumes	3
Welcoming team and needs	3
Planning	4
Decor et Scenography	5
Stage	5
Anchor points for Chinese pole	5
Sound system	6
Attachment	7
Examples of anchors points	7
Photos Decor and Scenography	7
Sacem and support	8
Chinese pole anchor point map	9

TOURING TEAM AND CONTACTS

You will welcome **4 Acrobats / artists** who also take care of the technical set up.

Artistic direction, tour manager, production, diffusion, technic in advance:

Héloïse BOURGEOIS +33 (0)6 89 59 79 70 heloisebourgeois@gmail.com

Administration, signature of contracts and invoicing:

Les thereses +33 (0)5 61 07 14 29 thereses@lesthereses.com

LOGISTIC AND WELCOMING

TRAVEL

4 artists travel by truck with the acrobatic equipment. If we fly the organizer will ensure the transfer from the station or airport to the venue or the hotel.

DRESSING ROOMS AND CATERING

The organizer will give to the Company a clean dressing room for 4 persons with showers, sink and toilets.

Please provide the following: cookies, cheese, ham, bread, fresh fruit, dry fruit, fruit juice, hot drinks.

COSTUMES

The organizer will provide the necessary equipment to clean the costumes (washing machine, dryer).

WELCOMING TEAM

We need

1 Technical director

1 Stage manager

1 Sound technician for set up, balance and present during the show

It is important to have 3 people helping for the installation of the poles.

The details for the presence of the staff are specified in the planning.

If the organizer is not able to provide all the requested staff, please contact us.

Our needs:

- Help to dig our tent clips if we use ours.
- Mop and water to clean the stage.
- 2 tarpaulins of 8m x 8m (or larger) in case of rain to protect our equipment during the set up.
- Space to park truck.



Contact : Héloïse BOURGEOIS

+33 (0)6 89 59 79 70

heloisebourgeois@gmail.com

PLANNING

When the company arrives, the sound patch must be wired and in working order.

The sound system calibrated.

The anchors points for the poles have to be installed before and ready to be used.

Basic schedule / Planning Type Day of the show – Set up / Representation / Break down
--

	Schedule	Action	Technical director	Sound technician	Stage manager
1 ^{er} service/ Set up Repetition Rehearsal	2H	Unloading of the truck / Set up of Chinese pole, and mats	1	1	1
		Sound balance / rehearsal	1	1	1
Break					
2ème Service Representation Break down	2H	Warm up and Representation	1	1	1
	1H	Break down / Loading of the truck	1	1	1
End of the day					

DECOR ET SCENOGRAPHY

The company will bring 3 Chinese poles.
The pole in front is 6.25 meters and the two behind are 5.65 meters.

STAGE

This show can be played frontal or circular.
The company moves without technician. If the show is scheduled in the evening, we need a light technician on site to program lights on the entire set.
The playground need to be 9 meters by 9 meters with sufficient space around for the anchor points.
The floor has to be smooth, flat and featureless.
The floor will be covered by mats of 8 meters by 7 meters brought by the Company.
If we play on stage it is sometimes better to reinforce under the stage where the Pole are placed.
The stage need to be cleaned before the performance with a wet mop.

IT IS IMPOSSIBLE TO PLAY WITH THE PRESENCE OF RAIN OR STRONG HUMIDITY. AND IT IS NECESSARY TO PLAY IN A SHADED AREA.

ANCHOR POINTS FOR CHINESE POLE

The manager of the Company will contact the technical team to validate the anchor points.

The poles will have to be guyed by cables. We need 4 anchor points on the ground, each supporting 500kg (big tent clamps, counterweights, water containers, chemical or mechanical sealing wall anchors points) and 2 others supporting 1000kg. The manager of the company will study the place of the points. (See the Plan of the poles in attachment)

The company provided

- 56 acrobatic puzzle mats to cover the ground on 8x7m
- 4 chairs
- 3 Chinese poles including head and foot
- 8 Cables
- 1 slings to connect the double pole
- 8 straps ratchet to put the tension on the poles
- Quick links
- Carabineers

SOUND SYSTEM

We don't have a stage manager or a sound technician on tour with us. Therefore, thank you for providing a sound technician (with all the necessary professional knowledge) to ensure the smooth running of the show.

ELECTRICITY

2 PC 16 with triplet (1 in front of the stage, the other at the computer level)

DIFFUSION ADRESS SYSTEM

Diffusion system adapted for optimal sound

L-R with subwoofer type L-Acoustics, D&B, ...

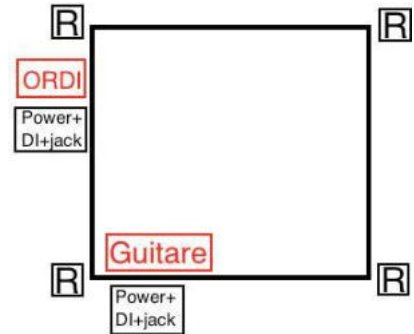

FOH CONTROL BOOTH

We need a digital board type Yamaha 12 entry 01V96 or else with at least 12 inputs and 4 outputs monitor + LR. We send CUES with QLAB during the show. (Our songs are in wave format).

The console (technical control) should preferably be placed stage right close to the backdrop in order to communicate as best as possible with the artists.

MONITORS (R-on the drawing)

The monitors are made from the FOH board. Thanks for providing 4 side fills on tripods type L-Acoustics MTD 112.

HF / MICROS

4 wireless receivers (Shure ULXD4, UR4D, GLXD4) :

-1 **beltpack** (Shure ULXD1, UR, GLXD1) with **JACK adaptators (6.35mm)**

-1 **DPA 4088** with ear-mouting skin colored (mounted on the right) + 1 **beltpack** (QLXD1...)

-2 **handheld wireless microphones** (ULXD2/SM58)



PATCH

CH	INSTR	MIC	COMMENTS
1	Voice	Micro HF	We bring the feets
2	Voice	Micro HF	
3	Voice	DPA 4088	BodyPack HF serre tête couleur chaire
4	GUIAR		BodyPack HF+ adapt jack (6,35mm)
5	PC left	DI (AR133 BSS)	Merci de fournir le câble mini-jack (stéréo) nécessaire
6	PC right	DI (AR133 BSS)	

Si toutefois quelque chose ne vous semble pas clair ou si vous êtes dans l'impossibilité de fournir le matériel demandé, merci de nous en informer à l'avance.

Contact : Héloïse BOURGEOIS

+33 (0)6 89 59 79 70

heloisebourgeois@gmail.com

ATTACHMENT

Examples of anchors points



Big tent clamps, Counterweights, Water containers,



Photos Decor and Scenography



Contact : Héloïse BOURGEOIS
+33 (0)6 89 59 79 70
heloisebourgeois@gmail.com

Music of the show “Entre Nous...”

Company ENTRE NOUS

- 1_ Geometria del universo, Collen, 5:51
- 2_ Che m’importa del mondo, Rita Pavone, 2:25
- 3_ Escenas de la vida en el borde, Chango Spasiuk, 5:34
- 4_ Miss you, Meute 3:30
- 5_ My baby just cares for me, Nina Simone, 3:38
- 6_ Version chantée par Entre Nous, « Johnny tu n’es pas un ange », musique originale Les Paul, Parole Francis Lemarque, 3 min
- 7_ The Mysterians, Messer chups, originale (2m14) Montage de 3:258_ My baby just cares for me, Nina Simone, 3:38

Support and residency:

Coproduction et support:

Festival Complètement cirque de Montréal
Cirque Entre Nous
7 Tours productions
Circus Concept

Residency:

La Cigalière, Sérignan (34)
Embelli Bain Douche, Rochessadoule
Le Cheptel Aleikoum, Saint Agile
La Bau, Les Franqueses del Vallès (ES)

VUE 3D

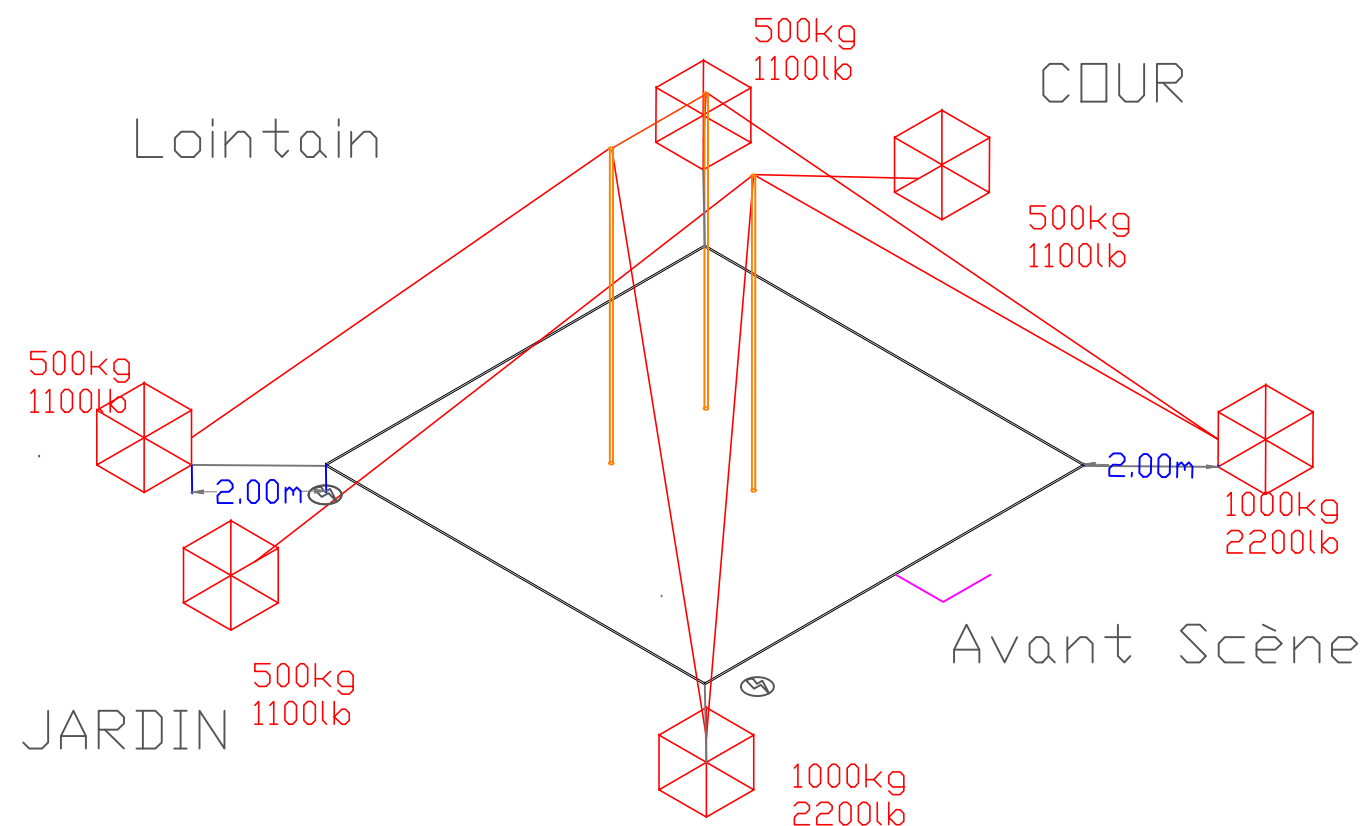

VUE de Dessus Lointain

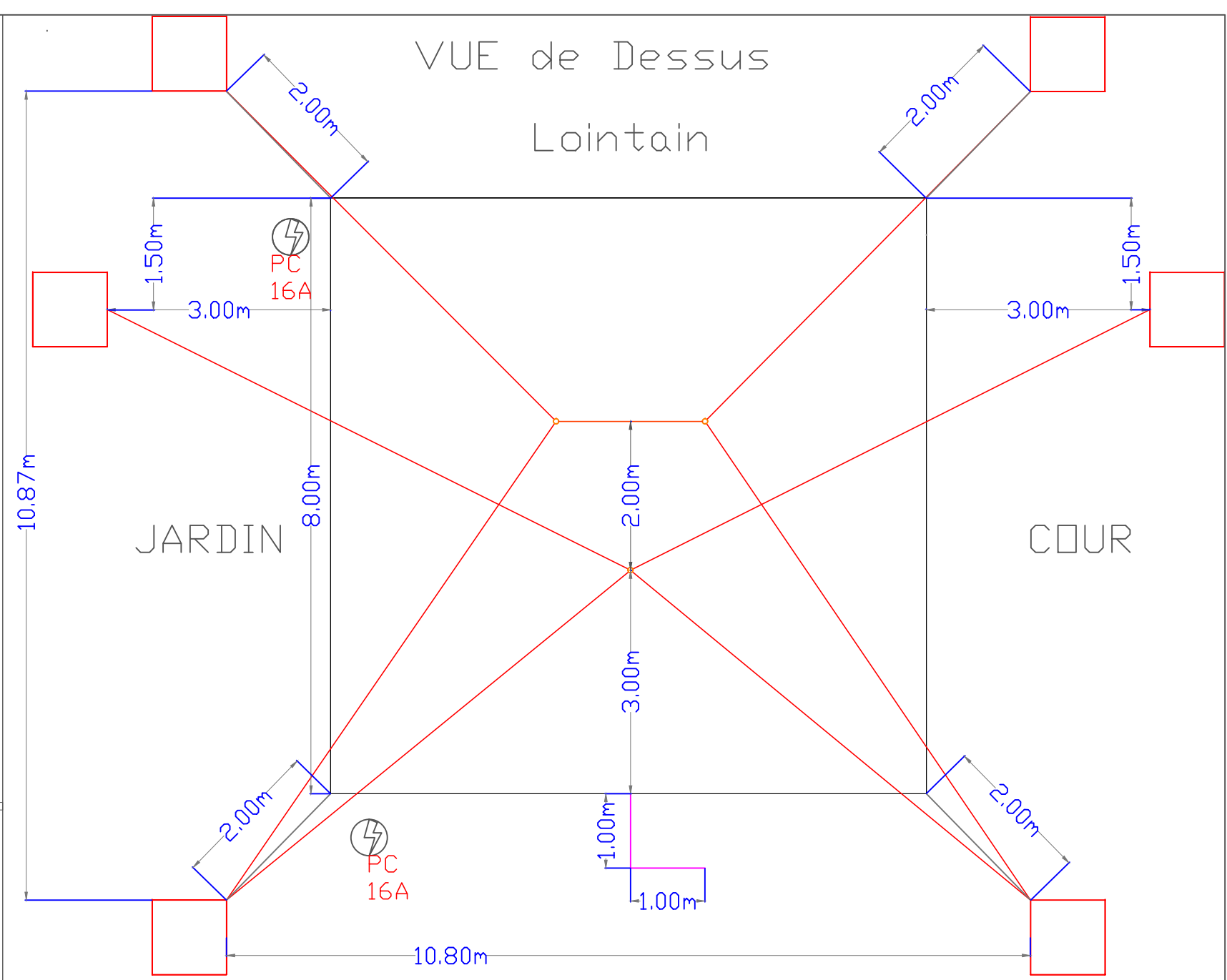

JARDIN

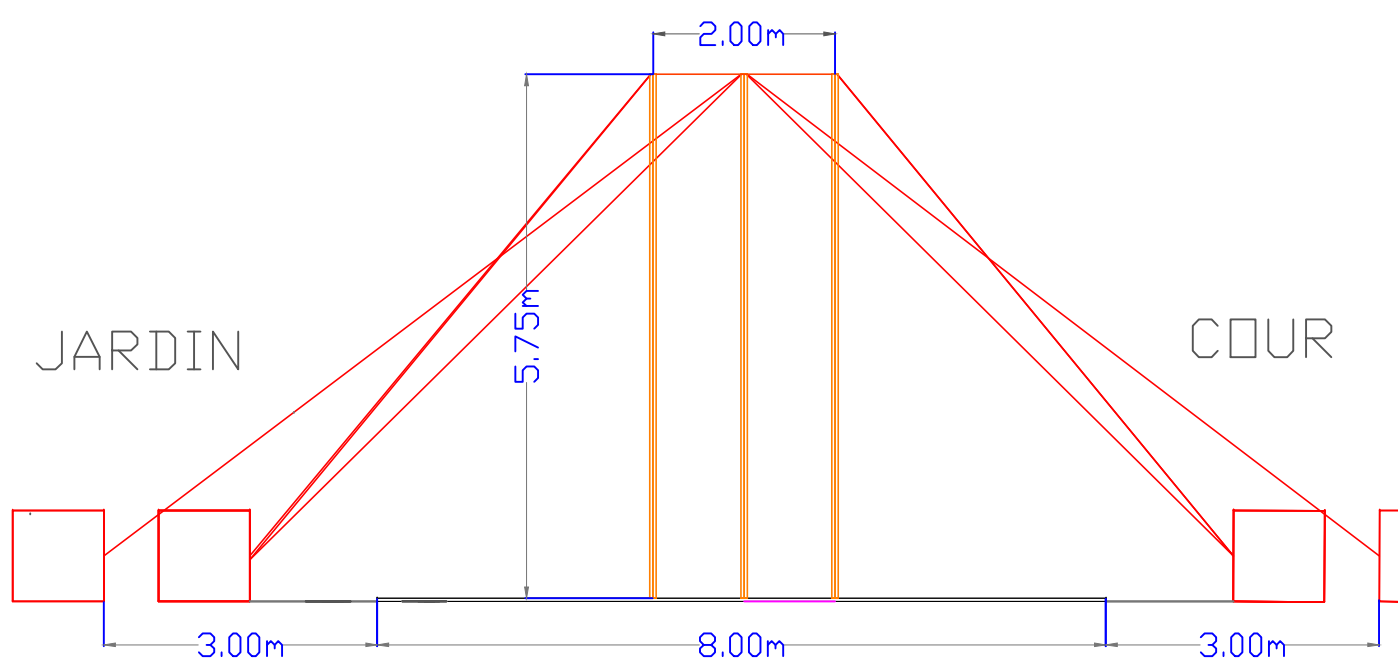

VUE De Face

Besoin de 6 points d'ancrage au sol
 4 supportant 500kg (lointain et mitar)
 et les 2 plus à la face avec un
 ancrage supportant 1000kg

Longueur des Haubans: 8m

Collectif ENTRE NOUS Contact : Héloïse BOURGEOIS +33 (0)6 89 59 79 70 heloisebourgeois@gmail.com					
SPECTACLE : Entre Nous...			DESIGNATION : Acrange & côtes Mâts		
Date Plan : 18/11/2020	Date Jeu :	Déssiné par :	Vue : Ensemble	Format : A3	Echelle :