

SHOW

« ENTRE NOUS... »

TECHNIQUE SHEET

**It is necessary to perform in a shaded area.
It is impossible to perform in conditions of high humidity or rain.**

*Show for 4 artists
Length of the show: 45 minutes
Audience between 200 and 1500 persons*

This technical sheet is an integral part of the contract. It must be initialled and signed in the same way as the rest of this contract. In case of difficulty to honour it, thank you to contact our team, at least 1 month before the date of the show.

Contents

Touring team and Contacts	2
Logistic and welcoming	3
Travel	3
Dressing rooms and Catering	3
Costumes	3
Welcoming team and needs	3
Planning	4
Decor et Scenography	5
Stage	5
Anchor points for Chinese pole	5
Sound system	6
Attachment	7
Examples of anchors points	7
Photos Decor and Scenography	7
Sacem and support	8
Chinese pole anchor point map	9

TOURING TEAM AND CONTACTS

You will welcome **4 Acrobats / artists** who also take care of the technical set up.

Artistic direction, tour manager, production, diffusion, technic in advance:

Héloïse BOURGEOIS +33 (0)6 89 59 79 70 heloisebourgeois@gmail.com

Administration, signature of contracts and invoicing:

Les thereses +33 (0)5 61 07 14 29 thereses@lesthereses.com

LOGISTIC AND WELCOMING

TRAVEL

Four artists travel by truck with the acrobatic equipment. If we fly the organizer will ensure the transfer from the station or airport to the venue or the hotel.

DRESSING ROOMS AND CATERING

The organizer will give to the Company a clean dressing room for 4 persons with showers, sink, toilets and a mirror.

Please provide a variety of cookies, cheese, ham, bread, fresh fruit, dry fruit, fruit juice, hot drinks.

COSTUMES

The organizer will provide (if possible) the necessary equipment to clean the costumes (washing machine and dryer).

WELCOMING TEAM

We need

1 Technical director

1 Stage manager

1 Sound technician for set up, balance and present during the show

It is important to have 3 people helping for the installation of the poles.

The details for the presence of the staff are specified in the planning.

If the organizer is not able to provide all the requested staff, please contact us.

Our needs:

- Ice packs and plastic bags nearby in case of injuries
- Mop and water to clean the stage.
- 2 tarpaulins of 8m x 8m (or larger) in case of rain to protect our equipment during the set up.
- Space to park our extended Renault Trafic van.
- If possible, a booth/quick tent near the stage
- If possible, provide carpets in front of the stage for children and for audience members wishing to sit down.



Contact : Héloïse BOURGEOIS

+33 (0)6 89 59 79 70

heloisebourgeois@gmail.com

PLANNING

When the company arrives, the sound patch must be wired and in working order.

The sound system calibrated.

The anchors points for the poles have to be installed before and ready to be used.

If possible, keep the pallet jack to facilitate the movement of the anchor's points.

Basic schedule / Planning Type Day of the show – Set up / Representation / Break down
--

	Schedule	Action	Technical director	Sound technician	Stage manager
1 ^{er} service/ Set up Repetition Rehearsal	2H	Unloading of the truck / Set up of Chinese pole, and mats	1	1	1
		Sound balance / rehearsal	1	1	1
Break					
2ème Service Representation Break down	2H	Warm up and Representation	1	1	1
	1H	Break down / Loading of the truck	1	1	1
End of the day					

DECOR ET SCENOGRAPHY

The company will bring 3 Chinese poles.

The pole in front is 6.25 meters and the two behind are 5.65 meters.

STAGE

This show can be played frontal or circular. It is still preferable to avoid having people seated behind the stage.

The playground needs to be 9 meters by 9 meters with sufficient space around for the anchor points. The floor has to be smooth, flat and featureless.

The floor will be covered by mats of 8 meters by 7 meters brought by the Company.

If we play on stage it is sometimes better to reinforce under the stage where the Pole are placed.

**It is necessary to perform in a shaded area.
It is impossible to perform in conditions of high humidity or rain.**

LIGHTING

The company travels without a stage manager. If the performance is scheduled in the evening, it is necessary to provide uniform lighting for the performance area, such as floodlights, with a technician on-site for installation and management of the lighting during the show.

- To light the performance area: Front floodlight with 4 floor-mounted spotlights, type PC 1000w Halogen/LED or Par 64 with CP62 (WFL) lamps.

- To light the Chinese poles: 8 PC 1000w Halogen/LED or Par 64 with CP62 (WFL) lamps, placed on the ground (2 spots at each corner of the stage).

ANCHOR POINTS FOR CHINESE POLE

The manager of the Company will contact the technical team to validate the anchor points.

The poles will have to be guyed by cables. We need 4 anchor points on the ground, each supporting 500kg (big tent clamps, counterweights, water containers, chemical or mechanical sealing wall anchors points) and 2 others supporting 1000kg. The manager of the company will study the place of the points. (See the Plan of the poles in attachment)

(We can also adapt with 4 points of 1000kg if the weights are large and can be attached to 2 separate points). →



The company provided

- 56 acrobatic puzzle mats to cover the ground on 8x7m
- 4 chairs
- 3 Chinese poles including head and foot
- 8 Cables + 1 slings to connect the double pole
- 8 straps ratchet to put the tension on the poles + Quick links + Carabineers

Contact : Héloïse BOURGEOIS
+33 (0)6 89 59 79 70
heloisebourgeois@gmail.com

SOUND SYSTEM

We do not travel with a sound engineer, and we do not provide any sound equipment. Please provide a qualified sound technician to ensure the smooth running of the show, as well as the sound equipment listed in the technical rider below.

ELECTRICITY

1 PC 16 with triplet at the computer level

DIFFUSION ADDRESS SYSTEM

Diffusion system adapted for optimal sound

L-R with subwoofer type L-Acoustics, D&B, ...

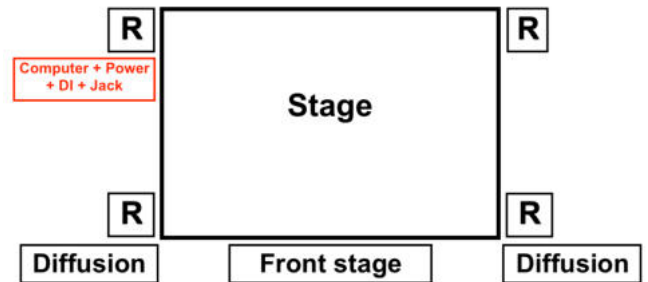

FOH CONTROL BOOTH

We need a digital board type Yamaha 12 entry 01V96 or else with at least 12 inputs and 4 outputs monitor + LR. We send CUES with QLAB during the show. (Our songs are in wave format).

The console (technical control) should preferably be placed stage right close to the backdrop to communicate as best as possible with the artists.

MONITORS (R-on the drawing)

The monitors are made from the FOH board. Thanks for providing 4 side fills on tripods type L-Acoustics MTD 112.

HF / MICROS

4 wireless receivers (Shure ULXD4, UR4D, GLXD4):

-1 belt pack (Shure ULXD1, UR, GLXD1) with JACK adaptors (6.35mm)

-1 DPA 4088 with ear-mounting skin colored (mounted on the right) + 1 belt pack (QLXD1...)

-2 handheld wireless microphones (ULXD2/SM58)+ the connection to screw on our micro stands.



PATCH

CH	INSTR	MIC	COMMENTS
1	Voice	Micro HF + support	We bring the stands
2	Voice	Micro HF + support	
3	Voice	DPA 4088	Body Pack HF serre tête couleur chair
4	GUITAR		Bodypack HF+ adapt jack (6,35mm)
5	PC left	DI (AR133 BSS)	Please provide the necessary mini-jack (stereo) cable.
6	PC right	DI (AR133 BSS)	

If anything is unclear or if you are unable to provide the requested equipment, please let us know in advance.

Contact : Héloïse BOURGEOIS

+33 (0)6 89 59 79 70

heloisebourgeois@gmail.com

ATTACHMENT

Examples of anchors points



Big tent clamps, Counterweights, Water containers,



Photos Decor and Scenography



Contact : Héloïse BOURGEOIS
+33 (0)6 89 59 79 70
heloisebourgeois@gmail.com

Music of the show “Entre Nous...”

Company ENTRE NOUS

- 1_ Geometria del universo, Collen, 5:51
- 2_ Che m’importa del mondo, Rita Pavone, 2:25
- 3_ Escenas de la vida en el borde, Chango Spasiuk, 5:34
- 4_ Miss you, Meute 3:30
- 5_ My baby just cares for me, Nina Simone, 3:38
- 6_ Version chantée par Entre Nous, « Johnny tu n’es pas un ange », musique originale Les Paul, Parole Francis Lemarque, 3 min
- 7_ The Mysterians, Messer chups, originale (2m14) Montage de 3:25
- 8_ My baby just cares for me, Nina Simone, 3:38

Support and residency :

Coproduction et support :

Festival Complètement cirque de Montréal
Cirque Entre Nous
7 Tours productions
Circus Concept

Residency :

La Cigalière, Sérignan (34)
Embelli Bain Douche, Rochessadoule
Le Cheptel Aleikoum, Saint Agile
La Bau, Les Franqueses del Vallès (ES)

VUE 3D

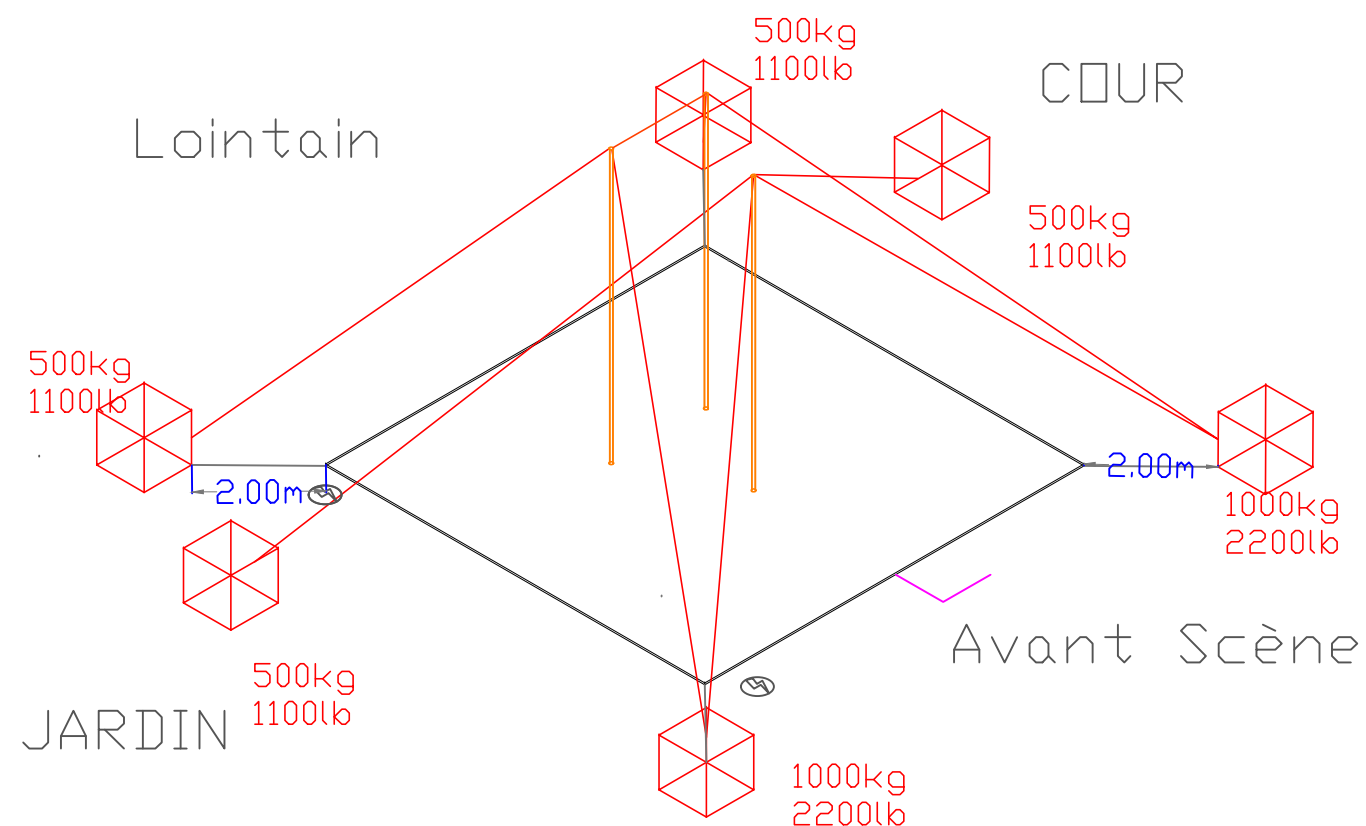

VUE de Dessus Lointain

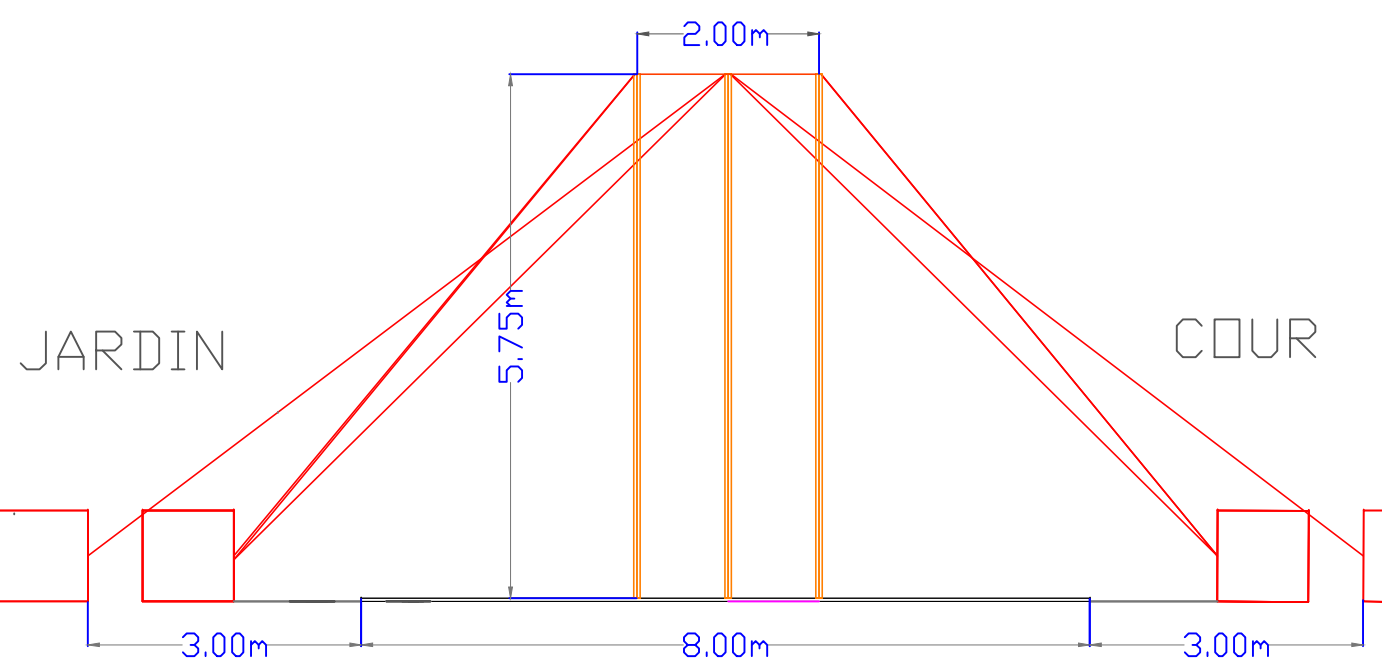
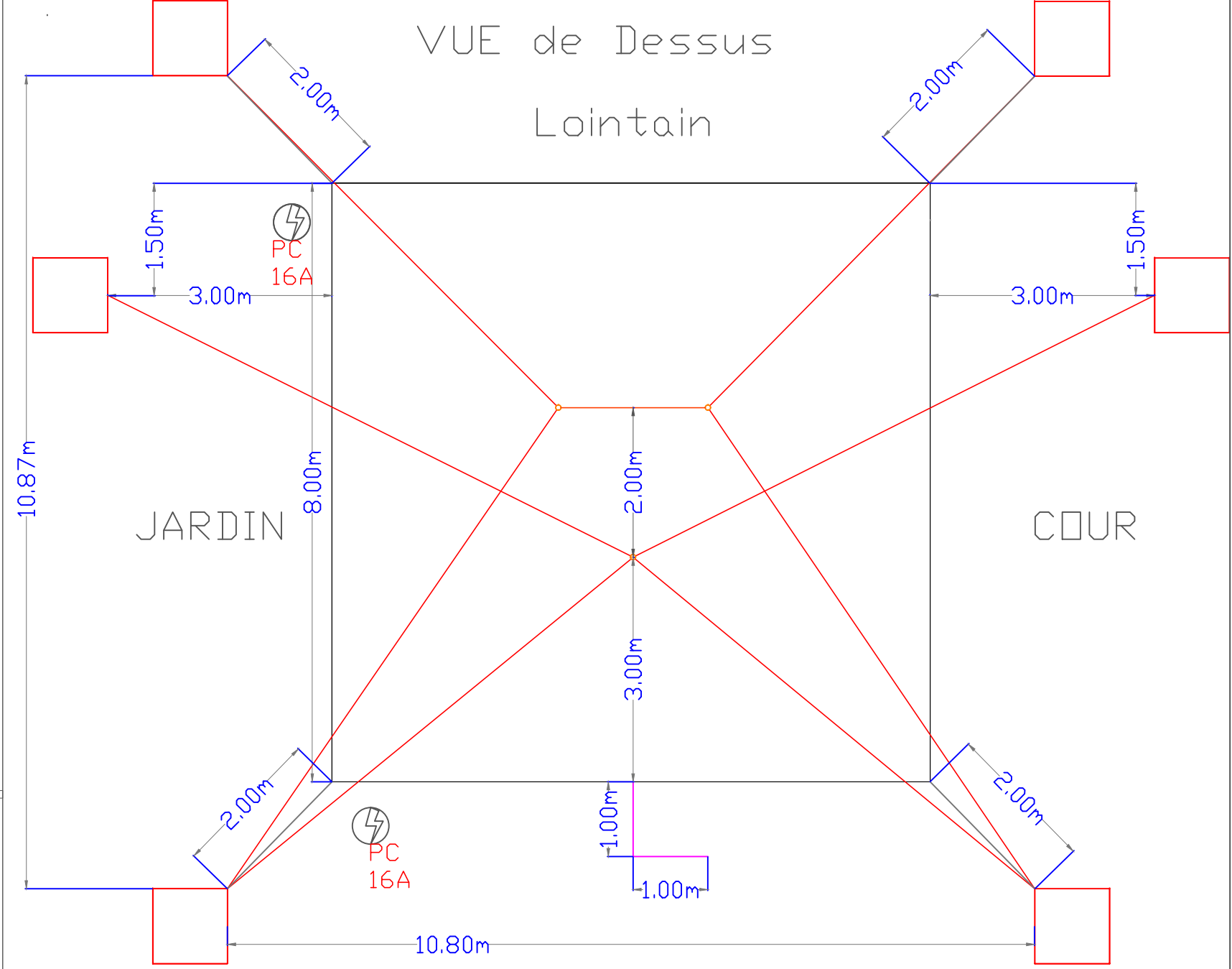

VUE De Face

Besoin de 6 points d'ancrage au sol
 4 supportant 500kg (lointain et mitar)
 et les 2 plus à la face avec un
 ancrage supportant 1000kg

Longueur des Haubans: 8m

Collectif ENTRE NOUS Contact : Héloïse BOURGEOIS +33 (0)6 89 59 79 70 heloisebourgeois@gmail.com					
SPECTACLE : Entre Nous...			DESIGNATION : Acrange & côtes Mâts		
Date Plan : 18/11/2020	Date Jeu :	Déssiné par :	Vue : Ensemble	Format : A3	Echelle :